



DA40 NG



airborne innovation

FACTS AND SPECIFICATIONS

DA40 NG facts and specifications

Power plant

Engine	Austro Engine AE 300 turbocharged common-rail injected 2.0 liter diesel engine with 168 HP and EECU single lever control system
Propeller	MT propeller MTV-6-R-/190-69 3-blade constant speed propeller
Fuel grades	Jet A-1, Jet A, TS-1 (Russia, Ukraine), RT (Russia, Ukraine), No. 3 Jet Fuel (China), JP-8

Performance (max. mass)

Max. speed (14,000 ft, MCP)	285 km/h TAS	154 kts TAS
Cruise speed at 60% (14,000 ft)	231 km/h TAS	125 kts TAS
Stall speed, landing configuration	107 km/h CAS	58 kts CAS
Rate of climb (ISA SL)	3.5 m/s	690 ft/min
Range at 60% (incl. auxiliary tank)	1,741 km	940 nm
Consumption at 60%	19.7 lt/hr	5.2 US gal/hr
Take-off ground roll (ISA SL)	370 m	1,214 ft
Landing ground roll (ISA SL)	270 m	886 ft
Max. operating altitude	5,000 m	16,400 ft
Max. demonstrated crosswind	46 km/h	25 kts

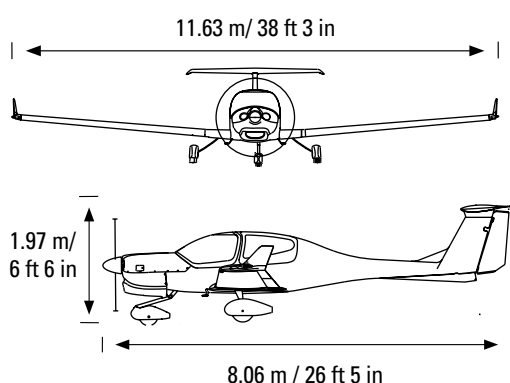

Dimensions / mass / loading

Seats	4	4
Empty weight	900 kg	1,984 lbs
Useful load	410 kg	904 lbs
Max. take off mass	1,310 kg	2,888 lbs
Fuel capacity total	147 lt	39 US gal
main tank	106 lt	28 US gal
auxiliary tank	41 lt	11 US gal

Diamond Aircraft Industries GmbH, Phone: +43 2622 26700, www.diamond-air.at

Specifications apply to standard equipped aircraft, if not otherwise stated. The above data are approximately specifications and may change without notice.

04/2015 S_30613E © 2015 Diamond Aircraft Industries GmbH